

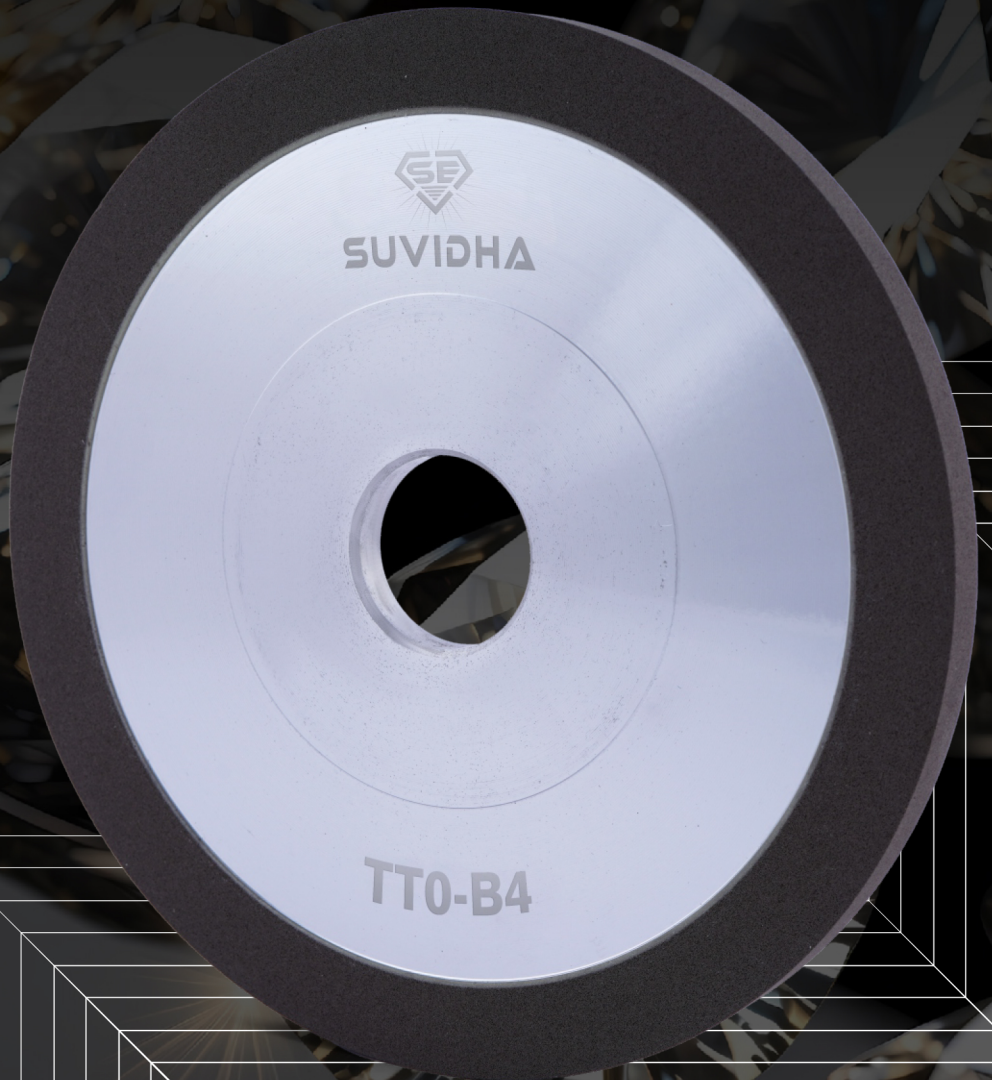

SVIDHA

ENGINEERING



AUG-2024

SOT BRUTING WHEEL CATALOGUE

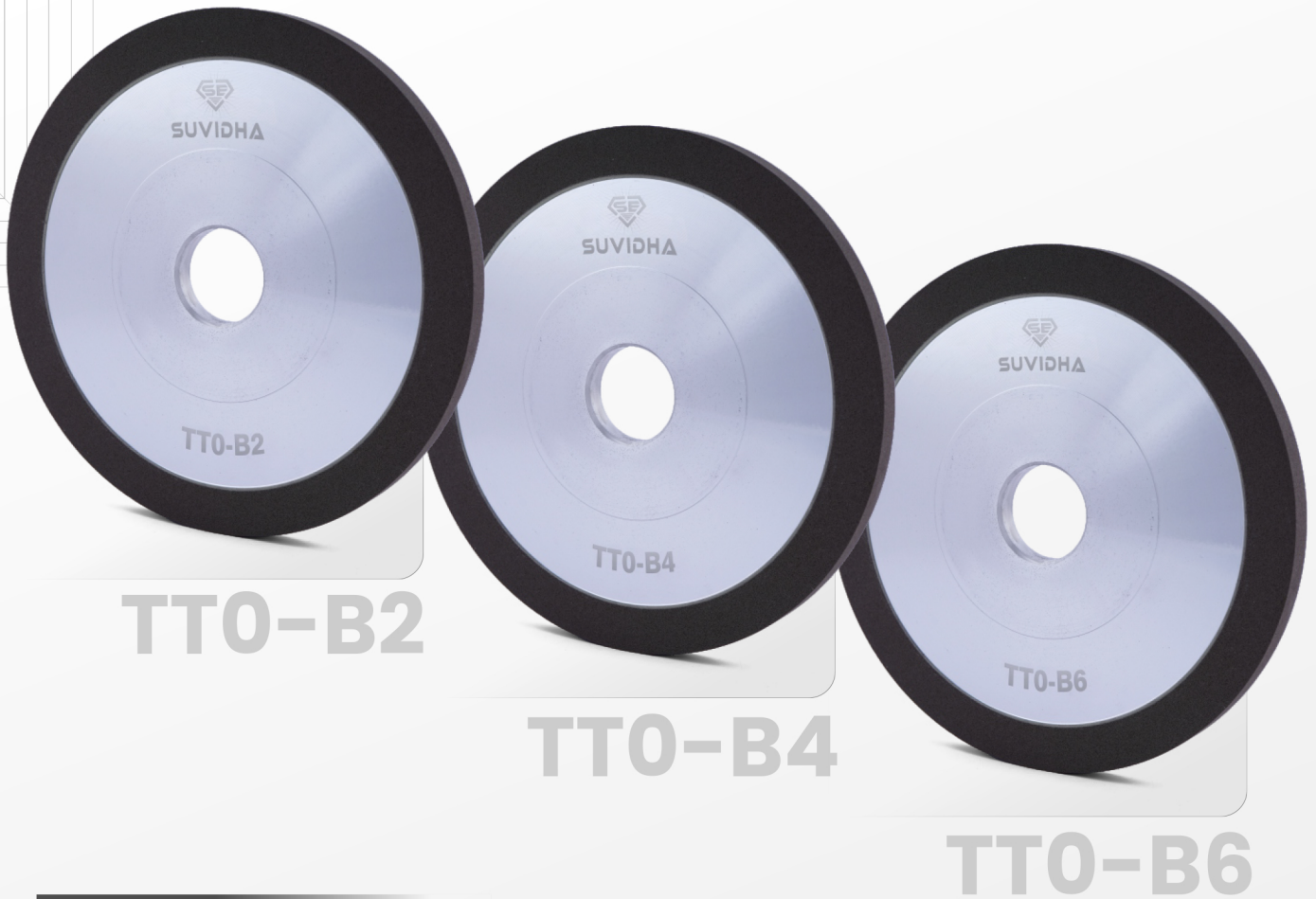

MODULE NAME : **TT0-B2, TT0-B4, TT0-B6**

COLOR : **Black** ●

TYPE OF USE : **High Pressure Stone**

ABOUT US

Primarily focused to cater risky and fragile nature of diamonds, Premium range tools provides high efficiency due to its superior quality. It caters to the application of precision cutting to attain required weight loss and to prevent damages. These tools cuts in a manner that doesn't heat up the diamond, that not only minimises any cause for damage but also presents utmost quality finishes. This range is best suitable for bigger and high-valued diamonds where the demand for consistency in performance result in greater productivity.



TECHNICAL DETAILS

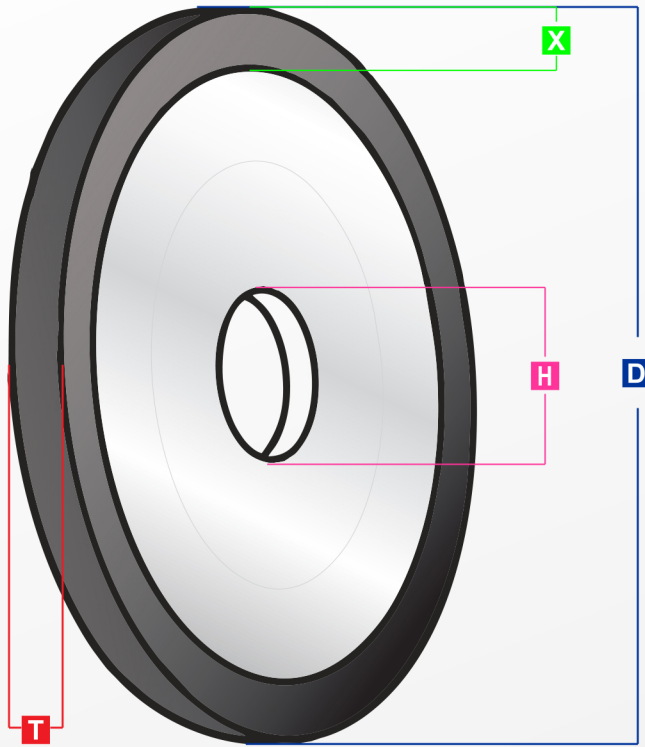

TTO-B2
TTO-B4
TTO-B6

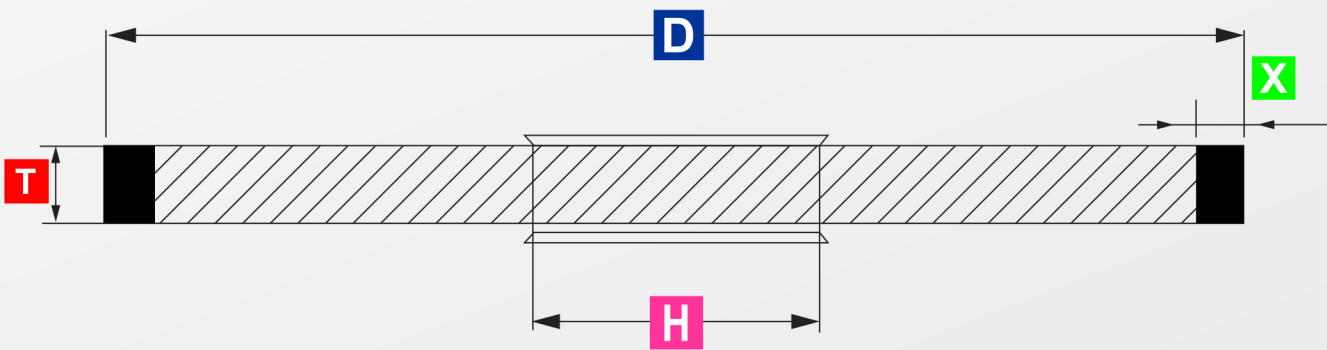

DIMENSIONAL DATA

D D	T T	X X	H H
175mm	10mm	15mm	32mm
175mm	8mm	15mm	32mm

**Yash
Manubhai**

☎ **+91 63563 83150**

☎ **+91 98251 34261**



SUVIDHA

**Manufacturer and Exporter
Premium Quality Diamonds Wheels**

suvidhaengineeringsurat@gmail.com

107, Diwali Baug Ind. Estate, Ankur Chowkdi, A.K. Road, Surat-6.